

Figure 1

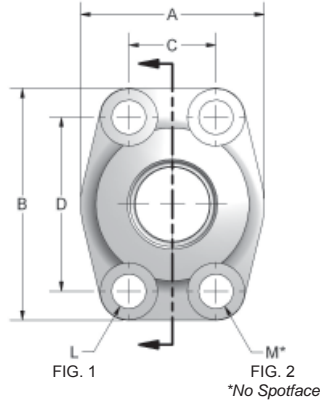

Figure 2

CODE 61 DEEP SOCKET WELD - TUBE																	
PART NO. O-RING FIG. 1	PART NO. FLAT FACE FIG. 2	TUBE SIZE	PAD SIZE	A	B	C	D	E	F	G	H	J	K	L	M UNC-2B	MOUNTING HARDWARE	
																O-RING	SHCS
W51-12-12	W5-12-12	.75	.75	1.97	2.56	.875	1.875	1.42	.71	1.250	.625	.752	.560	.406	3/8-16	214	3/8-16X1.50
W51-16-12	W5-16-12	1.00	.75	1.97	2.56	.875	1.875	1.42	.71	1.250	.750	1.002	.560	.406	3/8-16	214	3/8-16X1.50
W51-16-16	W5-16-16	1.00	1.00	2.17	2.75	1.031	2.062	1.50	.71	1.560	.875	1.002	.630	.406	3/8-16	219	3/8-16X1.50
W51-20-16	W5-20-16	1.25	1.00	2.17	2.75	1.031	2.062	1.50	.71	1.560	1.000	1.252	.630	.406	3/8-16	219	3/8-16X1.50
W51-20-20	W5-20-20	1.25	1.25	2.68	3.12	1.188	2.312	1.61	.83	1.750	1.125	1.252	.690	.469	7/16-14	222	7/16-14X1.75
W51-24-20	W5-24-20	1.50	1.25	2.68	3.12	1.188	2.312	1.61	.83	1.750	1.250	1.502	.690	.469	7/16-14	222	7/16-14X1.75
W51-24-24	W5-24-24	1.50	1.50	3.07	3.66	1.406	2.750	1.77	.98	2.115	1.375	1.502	.750	.531	1/2-13	225	1/2-13X1.75
W51-28-24	W5-28-24	1.75	1.50	3.07	3.66	1.406	2.750	1.77	.98	2.115	1.500	1.752	.750	.531	1/2-13	225	1/2-13X1.75
W51-32-32	W5-32-32	2.00	2.00	3.54	4.00	1.688	3.062	1.77	.98	2.490	1.875	2.002	.870	.531	1/2-13	228	1/2-13X1.75
W51-36-32	W5-36-32	2.25	2.00	3.54	4.00	1.688	3.062	1.77	.98	2.490	2.000	2.252	.870	.531	1/2-13	228	1/2-13X1.75
W51-40-40	W5-40-40	2.50	2.50	4.09	4.49	2.000	3.500	1.97	.98	2.995	2.375	2.502	1.000	.531	1/2-13	232	1/2-13X1.75
W51-44-40	W5-44-40	2.75	2.50	4.09	4.49	2.000	3.500	1.97	.98	2.995	2.500	2.752	1.000	.531	1/2-13	232	1/2-13X1.75

FLOW, NEEDLE & CHECK VALVES

HYDRAULIC BALL VALVES

WELD COUPLINGS

FLANGES